

HUGO OIL RUBBED BRONZE AUTOMATIC COMMERCIAL HANDS FREE FAUCET D508 SPECS

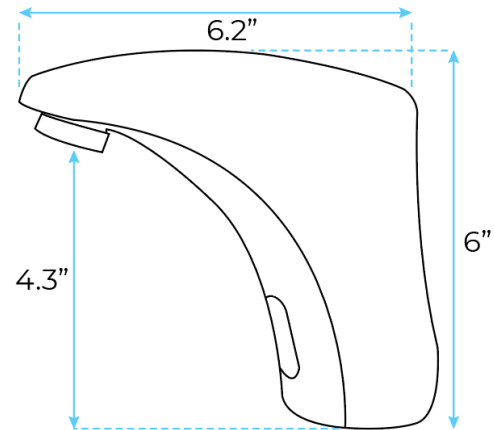

Specs:

Power: DC: 6V(4AA alkaline battery)
 AC: 220V-240V; 50/60HZ
 Water Consumption: 0.05Mpa-0.6Mpa
 Detection Zone: 16-32 cm or adjustable
 Motor valve lifespan: up to 500000 flushes
 Battery lifespan: 100000 cycles
 Static Power Consumption: 0.36mw
 Working Power consumption: 0.5mw
 Inductive Opening Time: < 1 second
 Inductive Closing Time: < 2 second
 Dia.of inlet / outlet pipe: G1/2"
 Flux: $\geq 0.07L/S$
 Temperature: 0.1-50°C
 Water Pressure: 0.1 - 7.0 KGS/cm 10 - 125 psi
 flow rate : 2.5 GPM

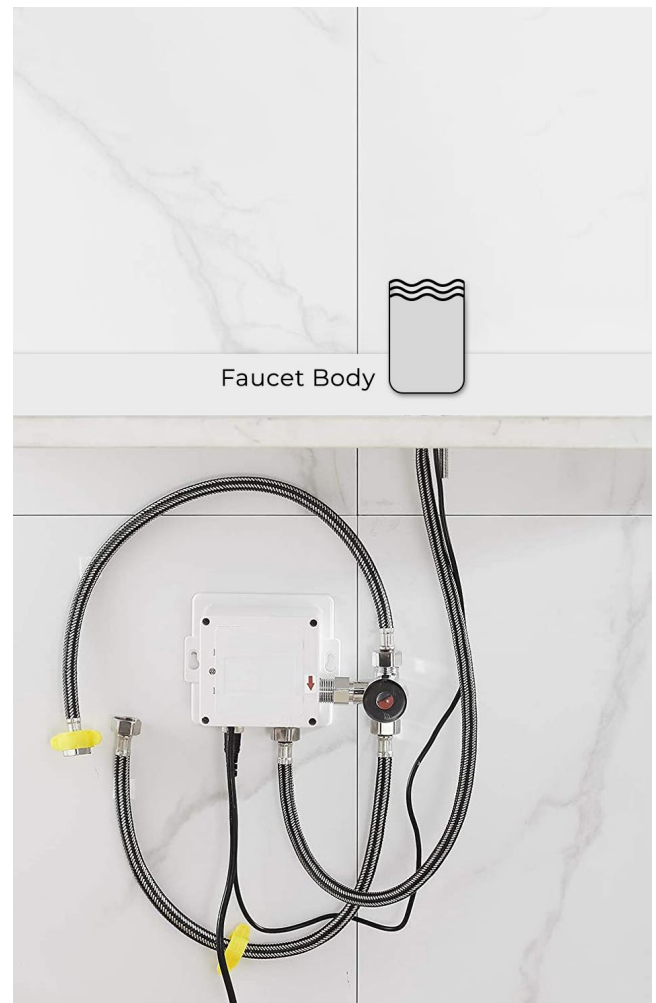

Other Details

[Product Details](#)